



Simply The Best!

# ANGLE CHECK VALVES

## SUCTION SYSTEMS

### Application -

Holds the prime in suction systems.

### Part Number - 401

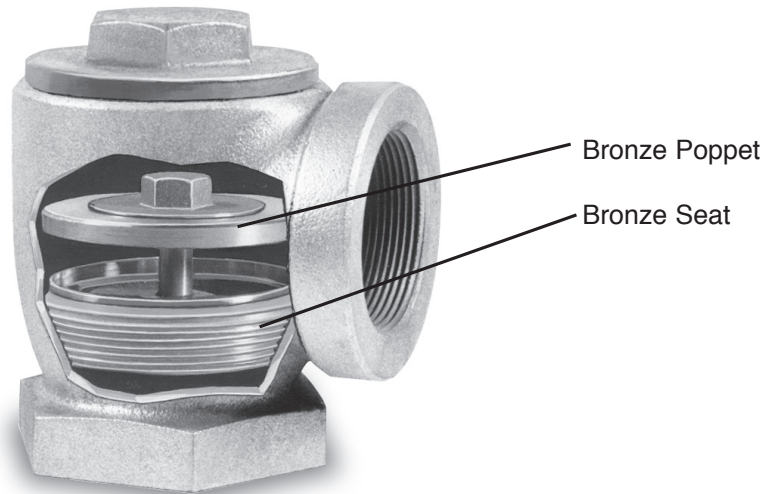

### Features -

- ✓ Ultra precise machined bronze seat and poppet for effectively holding the prime
- ✓ Cast iron body that eliminates any distortion of the valve seat while tightening

### Construction -

- Zinc plated cast iron body
- Precision bronze seat and poppet

Model	Thread Size	Weight (lbs.)	A	B
401-15	1-1/2"	4.6	4-5/8"	4"
401-20	2"	7.2	5-1/4"	5-1/8"

### Replacement Parts

Part Numbers	Description
401-15BC	1-1/2" Cap
401-20BC	2" Cap

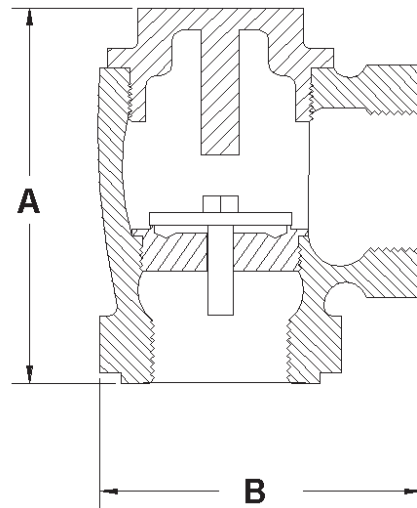

Notice: Universal Valve Co., products must be used in compliance with applicable federal, state, and local laws and regulations. Product selection should be based on physical specifications and limitations and compatibility with the environment and material to be handled. Universal Valve Co., makes no warranty of fitness for a particular use. All illustrations and specifications in this literature are based on the latest production information available at the time of publication. Prices, materials, and specification are subject to change at any time, and models may be discontinued at any time, in either case, without notice or obligation.

**UNIVERSAL VALVE COMPANY**

478 Schiller Street, Elizabeth, NJ 07206 • (800) 223-0741 • (908) 351-0606 • Fax: (908) 351-0369 • [universalvalve.com](http://universalvalve.com)

© 2017 Universal Valve Company, Inc.